

MULTICAM

DATASHEET

Multi-emission imaging using multiple cameras

Engineered for super resolution quality

With custom designed optics, the Cairn Multicam offers superior image quality on camera sensors up to 25mm diagonal. The unit accommodates three of our standard filter cubes allowing light to be distributed on the basis of wavelength, polarisation state or focal depth. Each cube has fine mechanical X-Y adjustment for pixel overlay or deliberate image offset. The input of the instrument has a variable rectangular aperture enabling the use of cropped sensor mode on all detectors. Each port can be fitted with different magnification optics to accommodate all popular sensor sizes and a wide range of fields of view. As the internal optics are infinity corrected, manual or motorised filter changers can also be fitted to input and output ports.

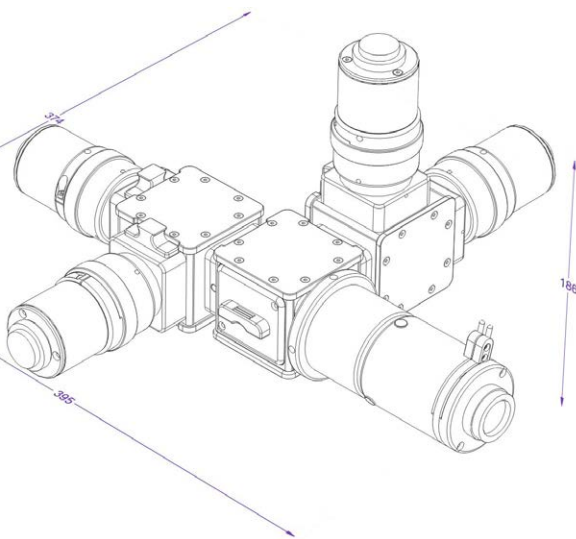

APPLICATIONS

- Förster Resonance Energy Transfer (FRET)
- Simultaneous use of multiple dyes or genetic markers
- Ratiometric imaging
- Polarisation studies
- Simultaneous transmitted light and fluorescence
- Simultaneous high speed and high resolution
- Simultaneous multi Z depth imaging

KEY BENEFITS

- Can be configured for up to 4 cameras and easily upgradeable
- Choice of magnifications (upon request)
- Simple alignment and focussing
- Rapidly interchangeable cubes
- Improved camera clamps for enhanced rigidity on both upright and inverted frames

MULTICHANNEL EMISSION SPLITTING RANGE

DATASHEET

NO.1 IN OPTICAL PERFORMANCE, STABILITY AND USABILITY



OptoSplit II & III

With an elegant configuration for simple side by side image splitting, the OptoSplit delivers high throughput imaging at a realistic price. Ideal for FRET, ratiometric imaging, polarisation studies and most simultaneous imaging applications requiring two or three images. User-configurable cubes and intuitive x, y adjustments offer convenience and simplicity.



Optosplit II Bypass

This builds on the success of the OptoSplit II, but adds a convenient single lever bypass mode making it more suitable for multi-user microscopes where simultaneous dual channel imaging is required for specific experiments alongside single wavelength recordings.



MultiSplit

Up to four channels simultaneously on one camera chip! The MultiSplit uses the four quadrants of a single camera in a 2x2 square format. The MultiSplit has the further possibility of simultaneous multi-depth imaging which is particularly attractive, as we can now do this at four depths rather than just two or three.



Multi Camera Adapters

Splitters for up to four channel imaging using multiple cameras (each). Perform simultaneous recording of multiple wavelengths, polarisation states or z depths using the full camera FOV without having to reduce their size. Variable rectangular aperture allows for the use of cropped sensor modes for the fastest speeds. Includes interchangeable camera mounts for C, F and T-mount cameras.



OptoMask

Enables precise FOV control for the high-speed, cropped sensor mode offered by several camera manufacturers including Andor and Teledyne..



OptoSpin 25 & 32

An intelligently designed, fast-spinning and stepping filter wheel, now with 25mm and 32mm wheels available and a range of microscope adapters. This slim unit has low inertia, enabling smooth operation and the ability to step between emission filters in 30ms, and spin continuously at 7500rpm when synchronised with a suitable light source. Change filters without moving the camera and mount two units together in the same 35mm optical path length for versatile combinations. (6 position for one filter wheel, 10 position for two).

